

BLDS2205 MANUAL

(V1.0)

BLDS2205 brushless DC motor driver is the latest high-tech product of our company for medium-power brushless motor. This product uses a large-scale integrated circuit to replace the original hardware design, with higher anti-interference and fast response. This product is suitable for driving any three-phase brushless DC motor, Hall or no Hall sensor, with peak current below 5A and power supply voltage between AC85V~264V. This driver features low temperature operation at high currents. The products are used in a series of electrical automation control fields such as knitting equipment, medical equipment, food packaging machinery and electric power tools.

Feature

- ◆ Current loop design, high torque at low speed, smooth operation
- ◆ High torque high speed output, the maximum speed reaches 10000rpm/min(depend on speed of motor)
- ◆ Speed control: 0-5V analog , PWM (10Hz-500Hz) ,RS485 communication control
- ◆ With signal input terminals EN (start/stop), DIR (direction), Brake
- ◆ With speed ,error signal output
- ◆ With protection function of over current, over voltage, under voltage and motor block

This product can achieve the following functions

- ◆ Speed open loop operation with hall sensor
- ◆ Speed close loop operation with hall sensor
- ◆ Speed open loop operation without hall sensor
- ◆ Speed close loop operation without hall sensor

Electrical Performance

(Ambient $T_j=25^{\circ}\text{C}$)

Power supply	AC85V~264V
Rated current	$\leq 5\text{A}$
Rated power	Max 1100W
Insulation resistance	$> 500\text{M}\Omega$ at normal temperature
Insulation strength	0.5KV, 1min at normal temperatures and pressures

Working Environment:

Cooling		natural cooling or forced air cooling
Working environment	Situation	avoid dust, oil mist and corrosive gases
	Temperature	0°C~+50°C
	Humidity	< 80%RH, no condensation, no frost
	vibration	< 0.5G (4.9m/s ²) 10Hz-60Hz, non-continuous operation
Storage temperature		-20°C~+65°C
Size		178*108*70mm
Weight		≈0.9Kg

[Note] Due to the drastic changes in the temperature of the storage and transportation environment, condensation or frosting is likely to occur. The driver only can be powered on when the temperature of the driver is consistent with the ambient temperature after being placed in this environment for more than 12 hours.

Instructions for the terminal

Function	Mark	Description
RS485 terminal	RS485+ RS485-	Connect PLC or computer to set driver
Control	BRK	Brake signal input, working on low level
	ALM	Alarm signal output. Output low level when error in driver
	+5V	power supply positive(Built-in power output)
	VSP	External speed control signal, 0-100% of the motor speed adjustment through external potentiometer to change VSP voltage, 0~5V
	FG	Motor speed pulse output, motor actual speed can be converted by measuring the frequency of this signal
	DIR	Motor CW/ CCW rotation control ,CCW when connect DIR to GND,CW when not connect DIR to GND
	EN	Motor enable control, EN is connected to GND, prohibiting the drive from running; EN is not connected to GND, allowing the drive to run.
	GND	Control signal ground
霍尔信号端	+5V	Hall power supply positive
	HA	Hall sensor signal A phase input
	HB	Hall sensor signal B phase input
	HC	Hall sensor signal C phase input
	GND	HALL power ground
电机及电源端	U、V、W	motor three-phase output signals
	GND、V+	AC85V~264V input

FUNCTION DESCRIPTION

Speed control mode (VSP)	<p>1. Connect with external potentiometer to adjust speed: connect the two fixed ends of the external potentiometer (5K~10K) to the GND and +5V terminals of the driver respectively. By connecting regulating terminal to the VSP terminal. The speed can be controlled by external potentiometer, or inputting analog voltage to VSP terminal through other control units (such as PLC, MCU, etc.). The voltage range of the VSP port is DC 0V~+ 5V, corresponding to the speed of motor from 0 to max speed.</p> <p>2. Input PWM signal to adjust speed: connect PWM signal positive terminal to VSP terminal and negative terminal to GND. By setting the +5V PWM signal with the frequency of 100Hz~100KHz, through PWM duty cycle change to achieve speed adjustment.</p>
Speed signal output (FG)	<p>The drive provides speed pulse signal of motor which is proportional to motor speed. Speed calculation method: motor speed (RPM) = $F \div N \times 60$ F = Actual frequency measured on the FG pin with the frequency meter N = motor poles pair (2 pairs pole motor $N=2$; 4 pairs pole motor $N=4$) For example, if the user selects a 4pairs poles motor, when the output FG signal is 200 Hz, motor speed = $200 \div 4 \times 60 = 3000$ rpm.</p>
CW/ CCW rotation (DIR)	<p>By controlling the high and low level transitions of DIR terminal to control rotation of the motor. Note: In order to avoid huge impact to motor and mechanical equipment when motor changes direction suddenly at high speed, the drive decelerate the motor until it stops when DIR terminal receives commutation signal, then the motor changes direction and accelerates to the set speed.</p>
Start/stop (EN)	<p>By controlling the high and low level transitions of EN terminal to control RUN/STOP of the motor. Motor runs normally when EN is in low level and stops when in high. When the start/stop is used to control the motor to stop, the motor stops naturally. Its motion law is related to load inertia. Factory setting is EN for allowed operation.</p>

Detailed error codes table

	Indicator light	Description	Note
1	stop one time when flickering twice	Under voltage Fault	
2	stop one time when flickering three times	Over voltage Fault	
3	stop one time when flickering four times	Over current Fault	
4	stop one time when flickering five times	Block rotation fault	The motor is not running or the motor wire is not connected
5	stop one time when flickering six times	short circuit fault	Motor coil open circuit or motor wire open circuit

Wiring diagram

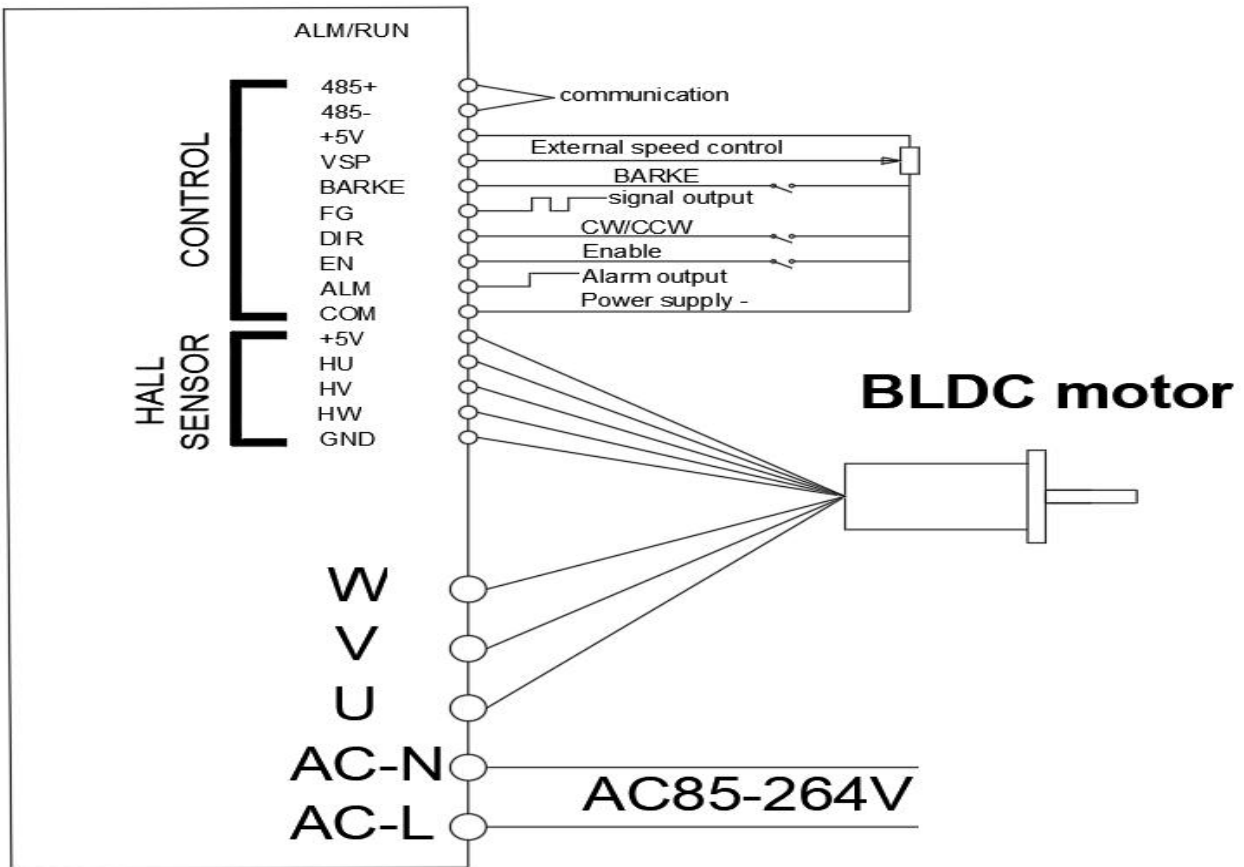

Dimensions(unit:mm)

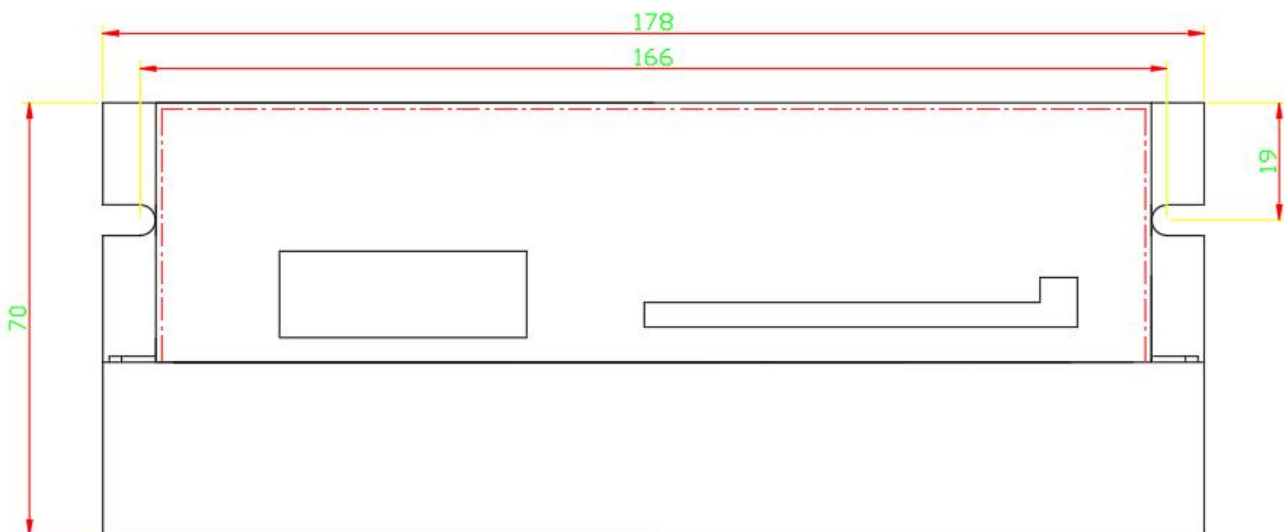

Safety Precautions

- ★Connecting motor and driver should be carried out under the condition of power failure
- ★Connect the power cable, motor winding wire and hall signal cable correctly according to the figure. Order of the UVW phases must be consistent.
- ★Do not disassemble the driver without instruction to prevent device damage
- ★Do not touch all terminals during power-on operation
- ★Do not operate the drive without housing
- ★Impacting the drive may cause damage

Q&A

1. How to use the drive for the first time?

After properly connecting the power cable, motor cable and Hall wire, the external potentiometer slowly accelerates. After the motor rotates correctly, it will test the functions such as enable and direction. If you are not familiar with this product, please install it to the actual occasion after test in initial use.

2. What happens if the power supply is reversed?

The Driver will be broken.

3. What is the maximum voltage of the upper control signal?

The maximum voltage of the speed control signal is 5V. The drive will be broken with voltage above 5V.

4. Housing of the driver is heated after long period of work, is it normal?

It is normal. At normal temperature, the housing reaches 90 degrees after a long period of work, which will not affect the performance.

5. The motor does not turn but shake when the power LED is on, what is the reason?

The phase wires and the hall wires may be connected incorrectly. Please test after wiring according to the motor manual.

6. Can I adjust my motor speed to 6000 with this driver?

The maximum speed of the brushless motor is determined by the parameters of the motor itself. Driver can control the motor speed from 0 to the max speed.

7. How can I connect this driver to my own motor?

Please make sure that the phase wires and Hall wires of the motor are defined before connecting. If you are not sure, please consult the motor manufacturer. Improper connect will cause damage to the driver.

8. Is it possible to add more function to this driver or develop new product?

Yes, please feel free to contact us.